

data sheet

Colenta[®]

FILM Processor

30 C41 30 SST



Colenta[®]

C41 Processor options for sheet and roll film
up to 30cm in width

09/2004 AN



C41 Film Processor

TYPE:COLENTA 30 C41 30 SST

Technical Specifications:

Processing applications: C41 Negative film

Max. Process width: max. 30 cm - 12 inch (4 Track loading of 35mm film)

Microprocessor Control: with 6 preprogrammable processing cycles

Transport Speed: 30 C41 30 SST - 30 cm per minute (at 3 min 15 sec Dev.Time)

(Dev. times are pre-programmable for push-pull processing)

***Tank capacities:* 30 C41 30 SST**

Developer	:	17,0
Bleach	:	8,0
FIX	:	8,0
FIX	:	8,0
STAB	:	8,0
STAB	:	8,0

Replenishment:

- Precisely controlled using opto-sensors to measure the film area loading.
- Activated after a pre-programmed film area is fed into the processor
- Antioxidation/standby replenishment, activated after 0-9 hours *

Solution Levels:

- Low Level monitoring in all tanks *
- High Level monitoring in Overflow Collection Tanks (waste management, optional) *
- Low Level in Repl. Tanks for Dev-, Bleach, Fix and Superstabi (optional) *

Temperatures: High / Low level monitoring for all the wet-tanks

Work in Progress : Details the location of film within the processor.

Transport:

- Drive motor overload monitoring
- Security cover lid switch

(* optional) - when activated will operate an audible warning and a message alert to confirm the error type.

Technical specification subject to change without notice.

Transport System:

COLENTA 30 C41 30 SST

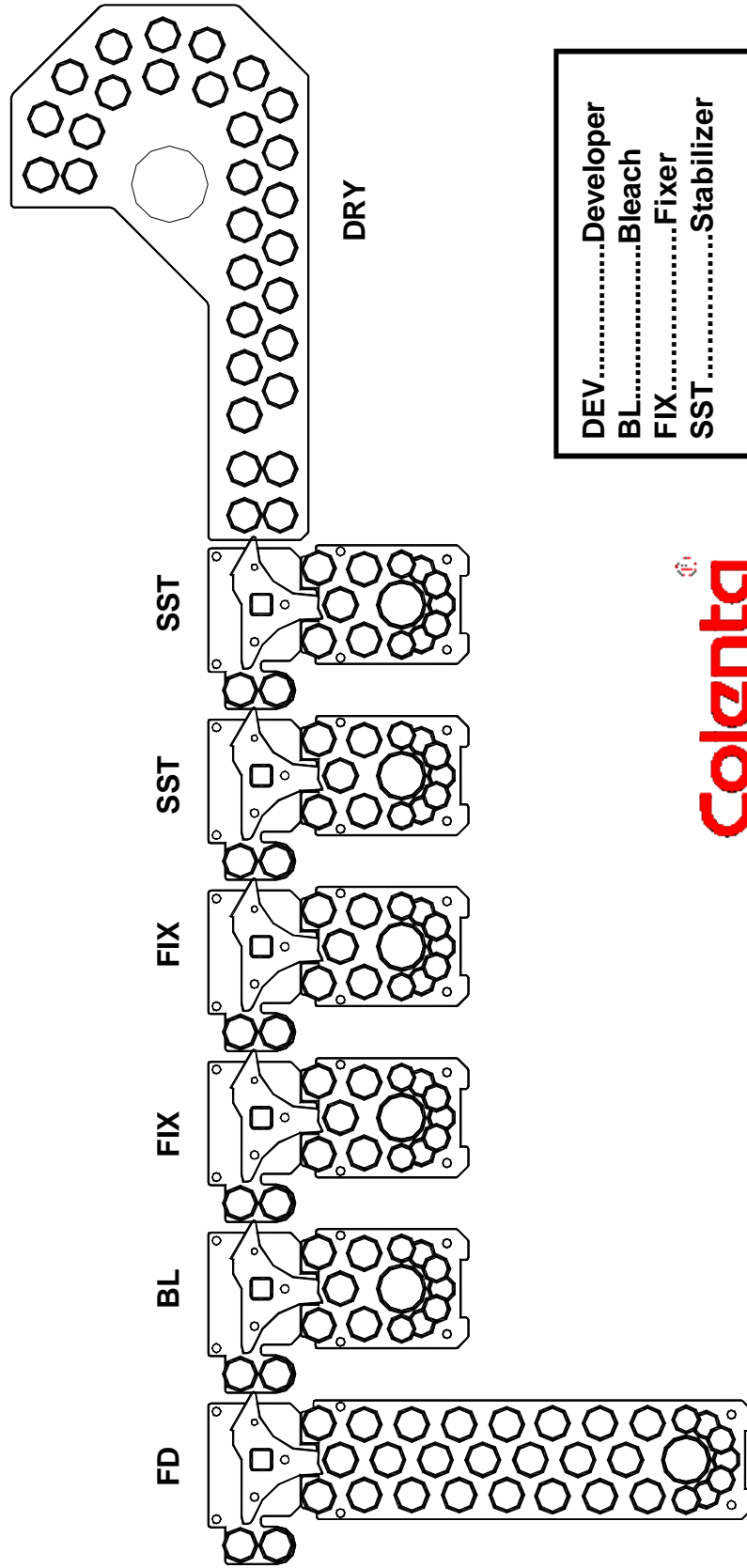

DEV.....Developer
BL.....Bleach
FIX.....Fixer
SST.....Stabilizer

 **Colenta**

DIMENSIONS for:

30 C41 30 SST

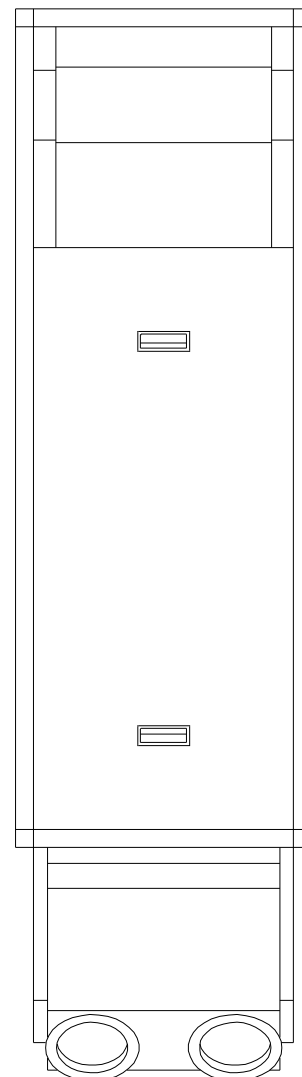
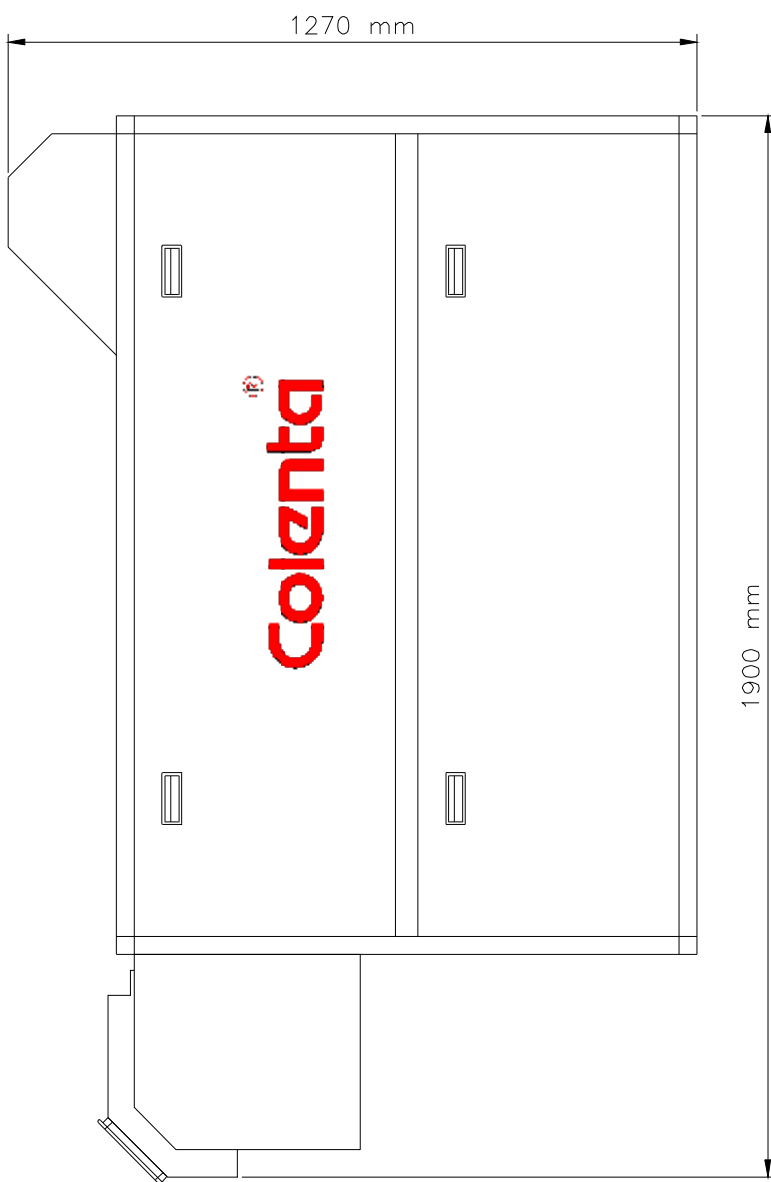
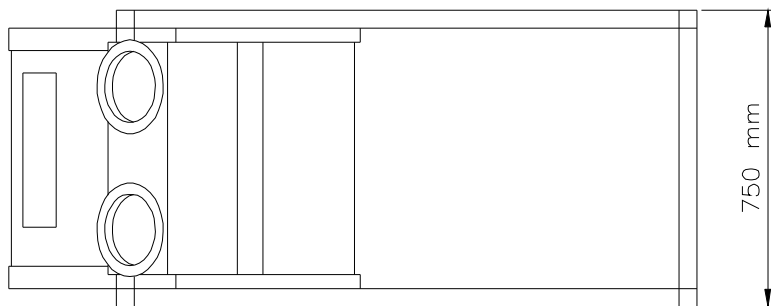

We recommend a minimum walking space of 60cm around the processor.

Electrical supply: (Standard, when 3N~400/230V, 50/60 Hz supply available)

30 C41 30 SST

5,2 kW

16 A

ATTENTION:
PROCESSOR TO BE CONNECTED TO
SUPPLY NET: 3N~380/220V 50/60Hz

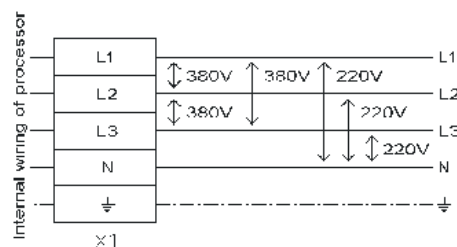

In case the above voltages are not available at site, please contact your local dealer or the factory for rewiring advice.

Alternatives, to be indicated when ordering

Details for shipment:

30 C41 30 SST

packing dimensions: 1 wooden box on palette
210cm x 93cm x 150cm (L x W x H)
packing volume: 2,93 m³
weight with packing: 410 kg